

# FASTest® BOR in TICK

ad us. vet.



In vitro diagnosticum

Test-kit for the qualitative detection of  
Borrelia antigens in the tick

## INSTRUCTIONS FOR USE



6912 Hörbranz – AUSTRIA  
www.megacor.com

## 1. INFORMATION ON THE TEST-KIT

### TEST-KIT COMPONENTS

1 test-kit FASTest® BOR in TICK contains:

- 1 or 5 test cassettes coated with monoclonal antibodies
- 1 dropper bottle A with 1.0 ml or 1.5 ml buffer diluent
- 1 or 5 sample tubes with squeezer
- 1 or 5 disposable plastic pipettes
- 1 tick remover
- 1 instructions for use

### STABILITY AND STORAGE



Store at  
15–25°C



Expiry date  
– see label

### APPLICATION AND ABBREVIATIONS



For veterinary use only

LOT

Lot number



In vitro diagnosticum



Do not use test-kit components from different kits, lot numbers or beyond stated expiry date.



Follow instructions for use precisely

T – TEST line, C – CONTROL line, LF – Lateral flow

### LIABILITY

The entire risk due to the performance of this product is assumed by the purchaser. The manufacturer shall not be liable for indirect, special or consequential damages of any kind resulting from the use of this product.

## 2. INTRODUCTION

Lyme borreliosis is present in animals and humans world-wide, mostly in the northern hemisphere. The castor bean tick *Ixodes ricinus* ("wood tick") is said to be the main vector for borrelia (spiral bacteria, Spirochaetaceae) of the *Borrelia burgdorferi* sensu lato (*B. b. s. l.*) complex. Ca. 19 species, among them the human-pathogen species *B. b. sensu stricto* (*B. b. s. s.*), *B. afzelii*, *B. garinii*, *B. bavariensis* and *B. spielmanii* belong to this complex. According to current knowledge, the pathogenicity for the dog is only proven for *B. b. s. s.*

Whether and how many *Borrelia* are contained in a tick is dependent on development stage of the tick, number of blood meals and on seasonal and geographical influences. Studies showed prevalence rates up to 50% in endemic areas. Reservoirs for *Borrelia* are small rodents, birds, roes and deer. Here, even larval and nymph-stage ticks get infected when sucking blood.

*Borrelia* live in the intestinal tract of ticks and are passed on to animals and humans via tick stings. About 12h after the sting, *Borrelia* located in the tick intestine are transferred via the salivary glands of the tick into the sting wound. The peak of *Borrelia* transmission is about 72h after sting.

Due to the long incubation time, symptoms like fever, varying lameness, lymphadenopathy, inflammation of muscles and joints appear not before weeks or months after the tick sting. The first and characteristic symptom for borreliosis in humans, a circular flush (Erythema migrans), is scarce in animals. Furthermore, it is often overlooked due to the fur.

The diagnosis and therapy of borreliosis in animals is often very difficult based on long incubation times, prolonged laboratory tests as well as the often unfavourable healing process. Thus, early diagnostics of the sucking tick is very important. So far, the direct detection of *Borrelia* in the tick only was possible with a time-consuming and costly test via PCR in a laboratory.

Using FASTest® BOR in TICK, potential *Borrelia* antigens in ticks can be detected fast, simple and reliable on-site. In case of a positive test result, diagnostic, therapeutic and prophylactic measures can be initiated immediately.

## 3. INFORMATION ON THE SPECIMEN MATERIAL

To remove the tick completely, including the head, the use of the attached tick remover is recommended! Special care must be taken that the tick is completely removed. Treat the wound!

Homogenise the sample material well before use!

The test procedure should be done immediately or maximum 48 hours after tick removal (risk of desiccation!). The tick can be stored in the sample tube until the test procedure starts.

Keep in mind that the sample material, as well as all used test-kit components, should have reached room temperature at the time of application.

## 4. SPECIMEN PREPARATION (Small and large tick)

- a. Open the sample tube and place the tick in the middle of the sample tube (fig.1).
- b. Squeeze the tick by closing the blue cap with the attached squeezer tightly onto the sample tube (fig.2).

### Small tick (Ø below 5 mm)

- c. Open the sample tube again. Hold the dropper bottle A vertically and add 4 drops of buffer diluent (ca. 160–200 µl). In case of any tick remnants on the squeezer, let the 4 drops flow over the squeezer into the sample tube (fig.3a).

- d. Mix the squeezed tick material homogeneously with the buffer diluent by twisting and untwisting the blue cap for several times (see fig.2).

### Large tick (Ø above 5 mm)

- c. No addition of buffer diluent!

## 5. TEST PROCEDURE

1. Remove the test cassette from its foil pouch shortly before use. Place it on a flat surface.

### Small tick (Ø below 5 mm)

2. Suck up the whole tick-buffer mixture (TBM, avoid tick particles if possible) using the disposable plastic pipette (fig.4a). Add 3 drops (120–150 µl) slowly (without air bubbles, one drop after the other) into the sample window S of the test cassette (hold pipette vertically, fig.5a). Rest volume, see chapter 9.

### Large tick (Ø above 5 mm)

2. Suck up the whole tick mixture (TM, avoid tick particles if possible) using the disposable plastic pipette (fig.4b). Add 1 drop (40–50 µl) into the sample window S of the test cassette (hold pipette vertically, fig.5b). Rest volume, see chapter 9.
3. Add 2 drops (80–100 µl) buffer diluent into the sample window S of the test cassette (fig.6).

If there is no beginning LF visible within 1 minute after adding the TBM (5.2) or the buffer (5.3), mix the TBM/the buffer in the sample window S with light pressure of the used pipette tip onto the membrane or add 1 drop of buffer diluent.

Tick check:



## 6. READING OF THE TEST RESULT



Read the test result 10 minutes after the three drops have been added into the sample window S. Beyond this time, test results should not be interpreted!

### POSITIVE TEST RESULT (fig.7)

A pink-purple TEST line of any intensity (varying from very weak to strongly intensive) and a pink-purple CONTROL line appear.

### NEGATIVE TEST RESULT (fig.8)

Only a pink-purple CONTROL line appears. This line indicates, irrespective of its intensity, that the test has been performed properly.

### INVALID TEST RESULT

No CONTROL line visible. The test should be repeated using a new test cassette.

fig.7  
POSITIVE TEST RESULT



fig.8  
NEGATIVE TEST RESULT

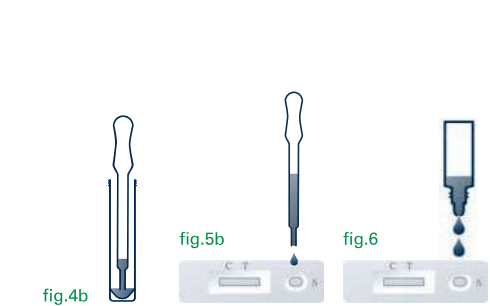
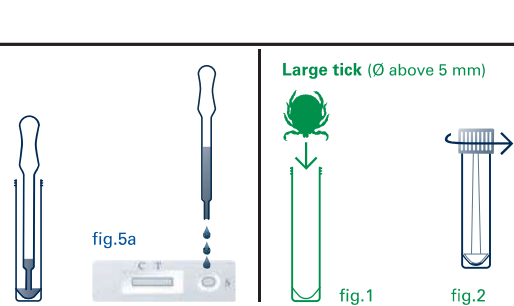
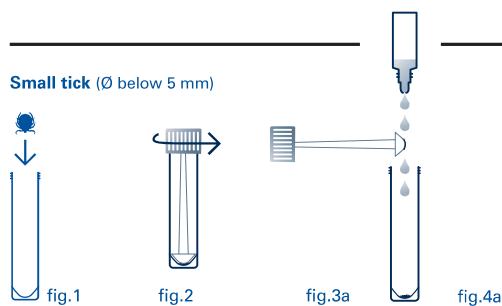

## 7. PRECAUTIONS FOR USERS

- Label sample material and associated test cassette to ensure a precise assignment.
- Use a new sample tube and a new pipette for each sample.
- The buffer diluent contains low concentrations of toxic sodium azide as a preservative, therefore avoid skin contact and/or ingestion.
- The sample material must be seen as potentially infectious for humans and disposed of accordingly, together with the used test-kit components.

## 8. TEST PRINCIPLE

The FASTest® BOR in TICK is based on an immunochromatographic "sandwich principle".

After dropping the tick-buffer mixture (TBM) into the sample window S, the *Borrelia* antigens present in the tick are bound to specific antibodies forming antigen-antibody complexes. These are migrating along the nitrocellulose membrane ("lateral flow", LF) and bind to fixed monoclonal anti-*Borrelia* antibodies conjugated with gold particles forming a pink-purple TEST line (T).

A correct test procedure will be indicated by a second pink-purple CONTROL line (C).

## 9. INFORMATION FOR THE INTERPRETATION

- The interpretation of the test result should always be based on anamnestic and clinical data as well as the therapy and prophylaxis possibilities.
- Any non-described colour or contour variation of T and C (e.g. greyish, shadow-like lines) has to be considered as unspecific reaction and therefore as negative test result.
- Positive test results may be observed earlier, depending on the concentration of antigen in the sample.
- Due to red hemoglobin background of the test membrane, caused by bloody sample material (large totally soaked up ticks), the visibility of T, especially in case of weak positive samples, could be from worse to not visible.
- T can vary both in intensity (from weak to strong pink-purple) and in width. Therefore, any pink-purple line which appears within the required incubation time has to be interpreted as a positive test result.
- Rest volume (TBM or TM) can be used for PCR confirmation.